

NAIL FIN INSTALLATION

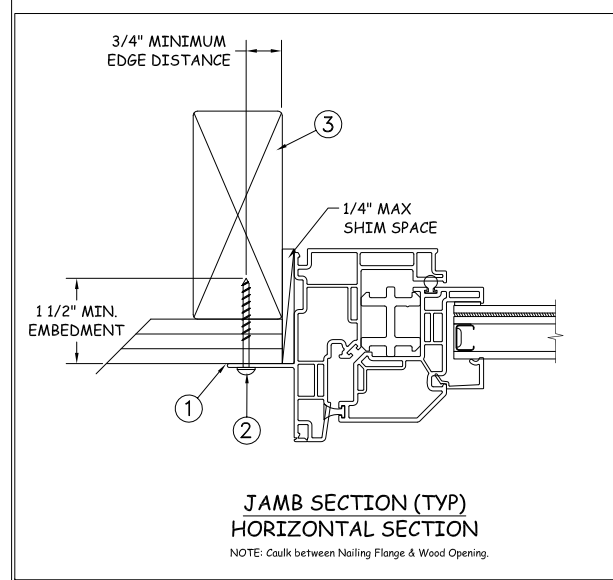
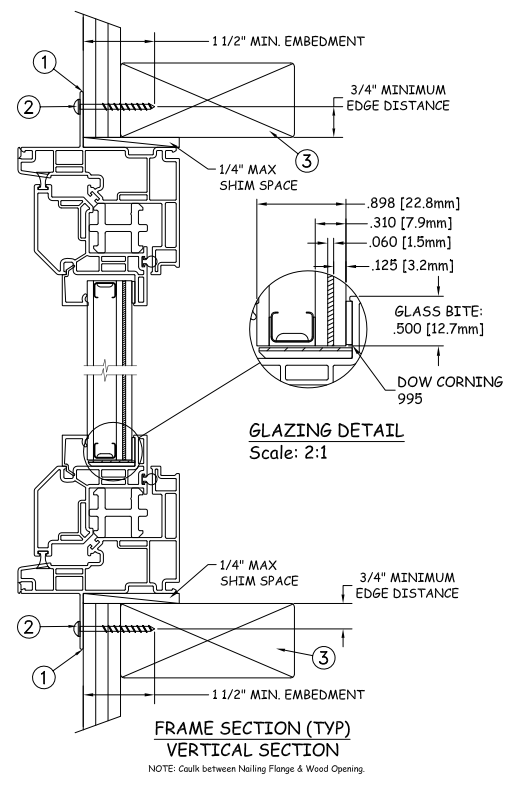
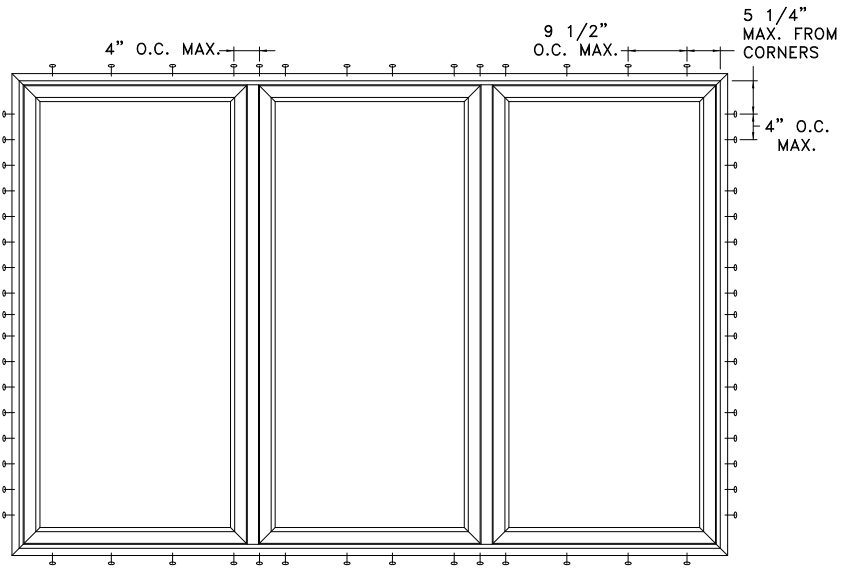

Max Frame	DP RATING	IMPACT
108 x 72	+50/-55	YES
WIND ZONE 2		

Installation Notes:

1. Seal flange/frame to substrate.
2. Use #8 PH or greater fastener through the nail fin with sufficient length to penetrate a minimum of 1 1/2" into the wood framing. For 2X wood frame substrate (min. S.G. = 0.42).
3. Host structure (wood buck, masonry, steel) to be designed and anchored to properly transfer all loads to the structure. The host structure is the responsibility of the architect or engineer of record for the project of installation.

General Notes:

1. The product shown herein is designed, tested and manufactured to comply with the wind load criteria of the adopted International Building Code(IBC), the International Residential Code(IRC), the Florida Building Code(FBC) excluding HVHZ and the industry requirement for the stated conditions.
2. All glazing shall conform to ASTM E1300.
3. At minimum, glazing shall be 3.0mm annealed - 11.8mm airspace - 3.0mm annealed - 1.52mm PVB Interlayer by DuPont - 2.5mm annealed insulated glass.
4. Use structural or composite shims where required.

This schedule addresses only the fasteners required to anchor the window to achieve the rated design pressure up to the size limitations noted. It is not intended as a guide to the installation process and does not address the sealing consideration that may arise in different wall conditions. For the complete installation procedure, see the instructions packaged with the window or go to www.jeld-wen.com.

DISCLAIMER:

This drawing and its contents are confidential and are not to be reproduced or copied in whole or in part or used or disclosed to others except as authorized by JELD-WEN Inc.

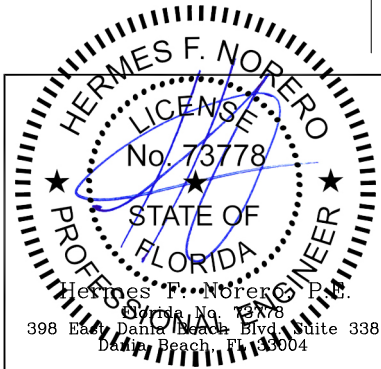

PROJECT ENGINEER: ---	DATE: 12/18/2017	JELD WEN 3737 Lakeport Blvd Klamath Falls, OR. 97601 Phone: (800) 535-3936
DRAWN BY: A. MCMILLAN	SCALE: NTS	
CHECKED BY: J. GOOSSEN	TITLE: Premium Vinyl Stationary Insash Casement Impact OOO - WZ2	
APPROVED BY: J. GOOSSEN		
PART/PROJECT No.:		
IDENTIFIER No. 110-17-049	PLANT NAME AND LOCATION:	CAD DWG. No.: PremVinylFixedCsmt Cert
	REV: A	SHEET 1 OF 4

MASONRY STRAP
INSTALLATION

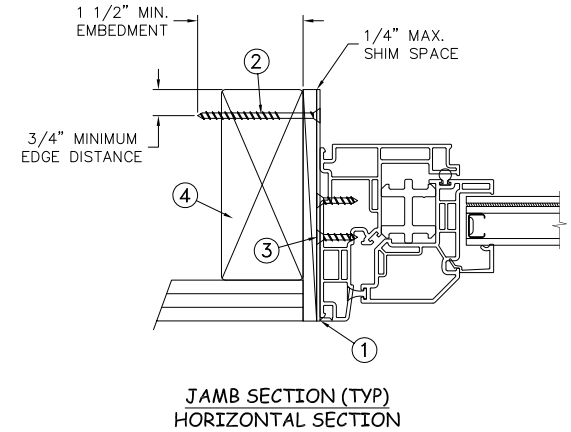
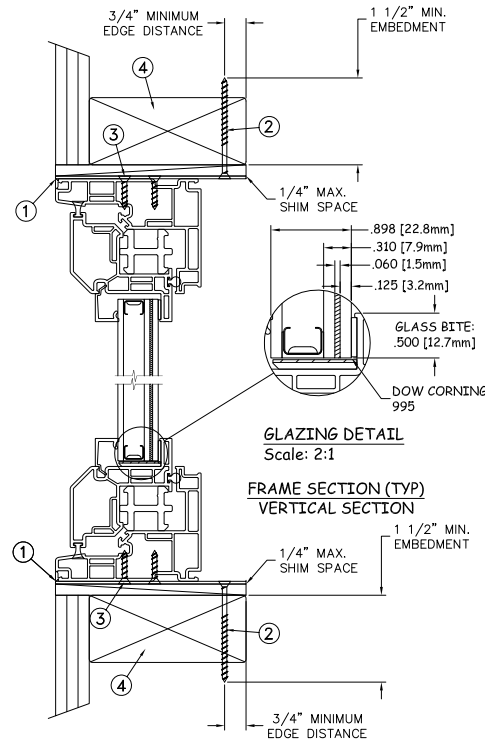
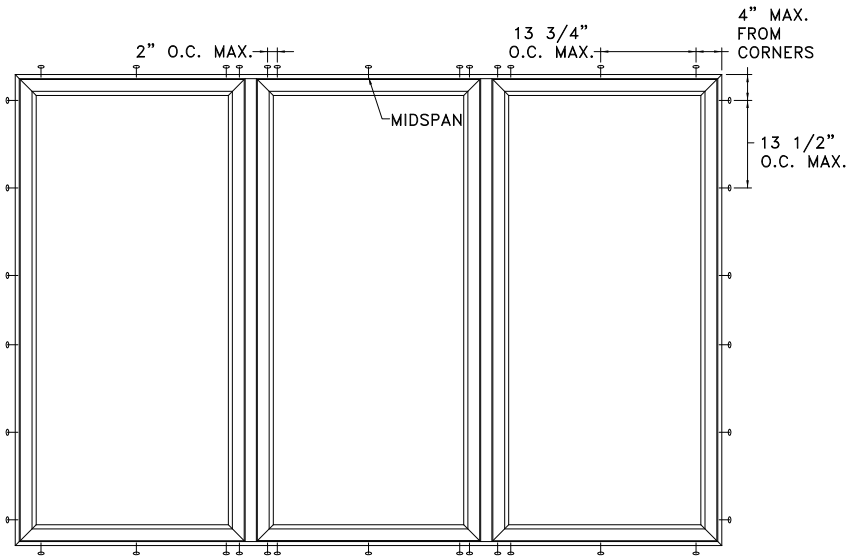

Max Frame	DP RATING	IMPACT
108 x 72	+50/-55	YES
WIND ZONE 2		

Installation Notes:

1. Seal flange/frame to substrate.
2. Use 2 - #8 PH or larger fastener through masonry strap with sufficient length to penetrate a minimum of 1 1/2" into the masonry or buck. For concrete (min. fc = 2000 psi) or masonry substrate (CMU shall adhere to ASTM C90).
3. Use 2 - #8 PFH or larger fasteners through masonry strap into jamb without penetrating through the jamb into product causing visibility or collateral damage to product.
4. Host structure (wood buck, masonry, steel) to be designed and anchored to properly transfer all loads to the structure. The host structure is the responsibility of the architect or engineer of record for the project of installation.

General Notes:

1. The product shown herein is designed, tested and manufactured to comply with the wind load criteria of the adopted International Building Code(IBC), the International Residential Code(IRC), the Florida Building Code(FBC) excluding HVHZ and the industry requirement for the stated conditions.
2. All glazing shall conform to ASTM E1300.
3. At minimum, glazing shall be 3.0mm annealed - 11.8mm airspace - 3.0mm annealed - 1.52mm PVB Interlayer by DuPont - 2.5mm annealed insulated glass.
4. Use structural or composite shims where required.

This schedule addresses only the fasteners required to anchor the window to achieve the rated design pressure up to the size limitations noted. It is not intended as a guide to the installation process and does not address the sealing consideration that may arise in different wall conditions. For the complete installation procedure, see the instructions packaged with the window or go to www.jeld-wen.com.

DISCLAIMER:

This drawing and its contents are confidential and are not to be reproduced or copied in whole or in part or used or disclosed to others except as authorized by JELD-WEN Inc.

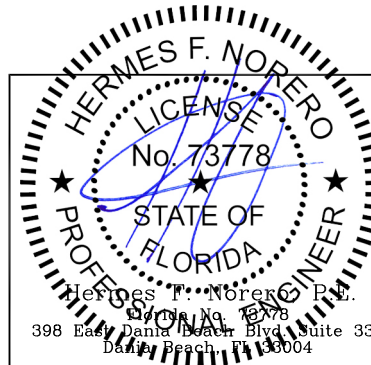

PROJECT ENGINEER: ---	DATE: 12/18/2017	JELD WEN 3737 Lakeport Blvd Klamath Falls, OR. 97601 Phone: (800) 535-3936
DRAWN BY: A. MCMILLAN	SCALE: NTS	
CHECKED BY: J. GOOSSEN	TITLE: Premium Vinyl Stationary Insash Casement Impact OOO - WZ2	
APPROVED BY: J. GOOSSEN		
PART/PROJECT No.: D014460		
IDENTIFIER No. 110-17-049	PLANT NAME AND LOCATION:	CAD DWG. No.: PremVinylFixedCsmt Cert
	REV: A	SHEET 2 OF 4

MASONRY INSTALLATION

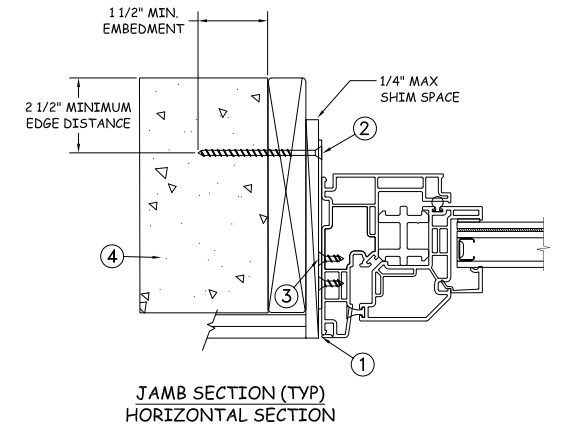
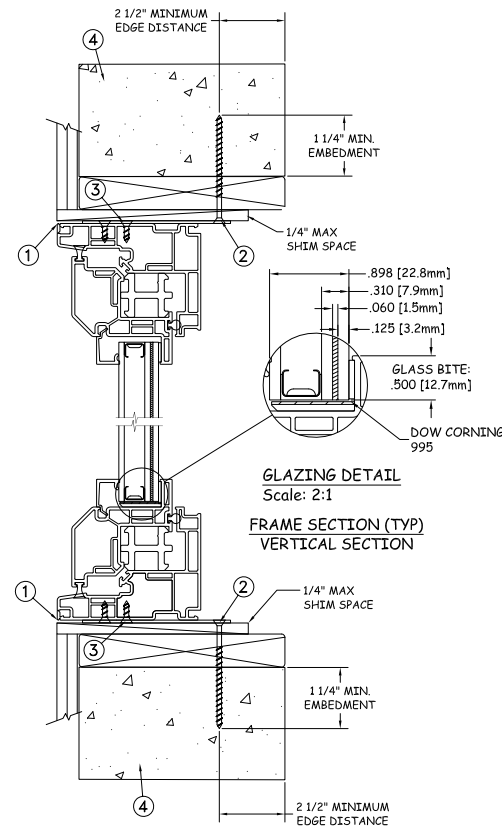
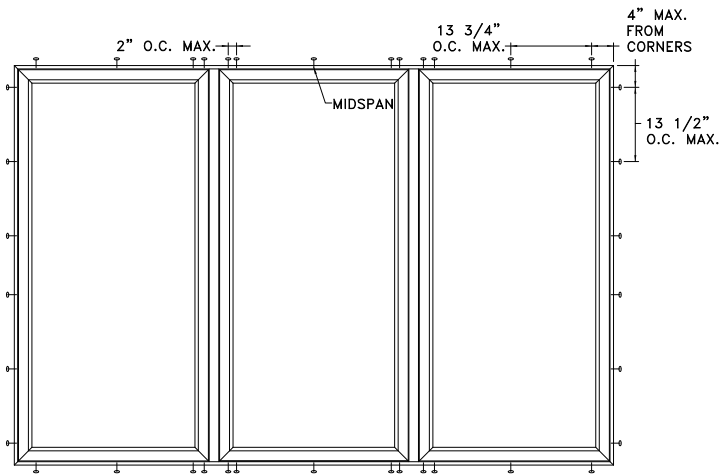

Max Frame	DP RATING	IMPACT
108 x 72	+50/-55	YES
WIND ZONE 2		

Installation Notes:

1. Seal flange/frame to substrate.
2. Use 1/4" Elco Tapcon or equivalent fasteners through the masonry straps with sufficient length to penetrate a minimum of 1 1/4" into concrete or masonry at each location with a 2 1/2" min from edge distance. For concrete (min. = 2000psi) or masonry (CMU shall conform to ASTM C90).
3. Use 2 - #8 PFH or larger fasteners through masonry strap into jamb without penetrating through the jamb into product causing visibility or collateral damage to the product.
4. Host structure (wood buck, masonry, steel) to be designed and anchored to properly transfer all loads to the structure. The host structure is the responsibility of the architect or engineer of record for the project of installation.

General Notes:

1. The product shown herein is designed, tested and manufactured to comply with the wind load criteria of the adopted International Building Code(IBC), the International Residential Code(IRC), the Florida Building Code(FBC) excluding HVHZ and the industry requirement for the stated conditions.
2. All glazing shall conform to ASTM E1300.
3. At minimum, glazing shall be 3.2mm annealed - 11.8mm airspace - 3.2mm annealed - 1.5mm PVB Interlayer by DuPont - 3.2mm annealed insulated glass.
4. Use structural or composite shims where required.

This schedule addresses only the fasteners required to anchor the window to achieve the rated design pressure up to the size limitations noted. It is not intended as a guide to the installation process and does not address the sealing consideration that may arise in different wall conditions. For the complete installation procedure, see the instructions packaged with the window or go to www.jeld-wen.com.

DISCLAIMER:

This drawing and its contents are confidential and are not to be reproduced or copied in whole or in part or used or disclosed to others except as authorized by JELD-WEN Inc.

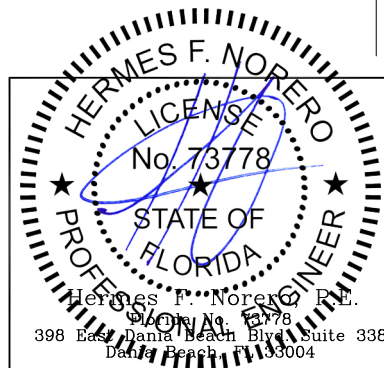

PROJECT ENGINEER: ---	DATE: 12/18/2017	JELD WEN	3737 Lakeport Blvd Klamath Falls, OR. 97601 Phone: (800) 535-3936	
DRAWN BY: A. MCMILLAN	SCALE: NTS			
CHECKED BY: J. GOOSSEN	TITLE: Premium Vinyl Fixed Casement Impact OOO Window - W22			
APPROVED BY: J. GOOSSEN				
PART/PROJECT No.:	D014460			
IDENTIFIER No. 110-17-049	PLANT NAME AND LOCATION:	CAD DWG. No.:	REV:	SHEET
		PremVinylFixedCsmt Cert	A	3 OF 4

STEEL INSTALLATION

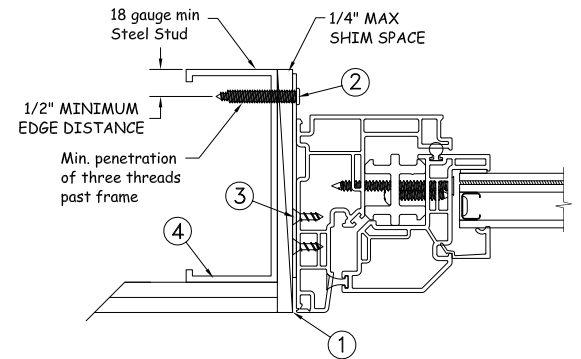
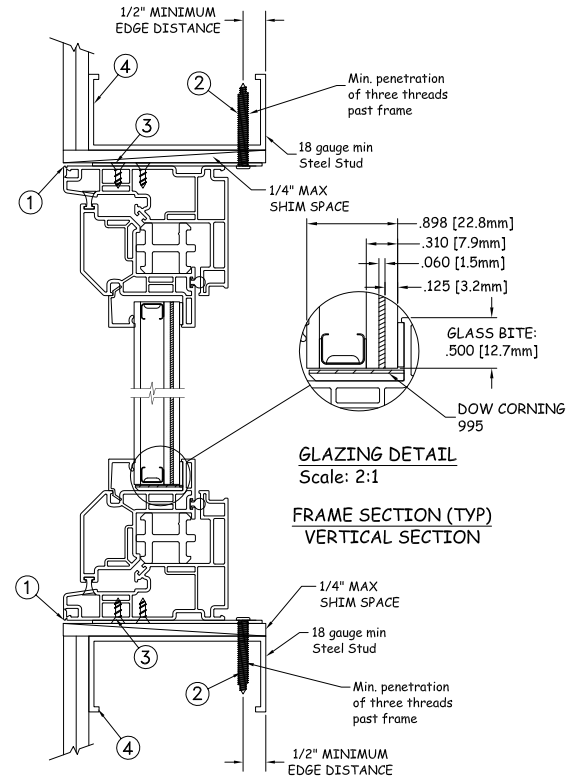
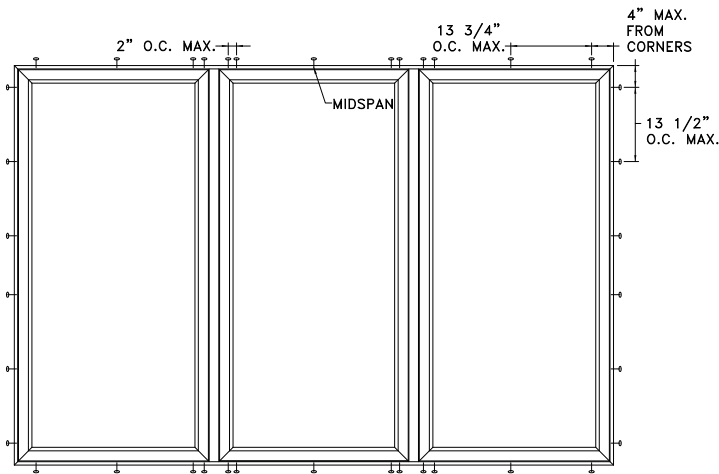

JAMB SECTION (TYP)
HORIZONTAL SECTION

Max Frame	DP RATING	IMPACT
108 x 72	+50/-55	YES
WIND ZONE 2		

Installation Notes:

1. Seal flange/frame to substrate.
2. For anchoring into metal framing, use #12 TEK Self Tapping screws through masonry strap with sufficient length to achieve a minimum penetration of three threads past the frame thickness. Locate anchors as shown in elevations and installation details. Steel substrate min. 18ga., fy = 33 ksi.
3. Use 2 - #8 PFH or larger fasteners through masonry strap into jamb without penetrating through the jamb into product causing visibility or collateral damage to the product.
4. Host structure (wood buck, masonry, steel) to be designed and anchored to properly transfer all loads to the structure. The host structure is the responsibility of the architect or engineer of record for the project of installation.

General Notes:

1. The product shown herein is designed, tested and manufactured to comply with the wind load criteria of the adopted International Building Code(IBC), the International Residential Code(IRC), the Florida Building Code(FBC) excluding HVHZ and the industry requirement for the stated conditions.
2. All glazing shall conform to ASTM E1300.
3. At minimum, glazing shall be 3.2mm annealed - 11.8mm airspace - 3.2mm annealed - 1.5mm PVB Interlayer by DuPont - 3.2mm annealed insulated glass.
4. Use structural or composite shims where required.

This schedule addresses only the fasteners required to anchor the window to achieve the rated design pressure up to the size limitations noted. It is not intended as a guide to the installation process and does not address the sealing consideration that may arise in different wall conditions. For the complete installation procedure, see the instructions packaged with the window or go to www.jeld-wen.com.

DISCLAIMER:

This drawing and its contents are confidential and are not to be reproduced or copied in whole or in part or used or disclosed to others except as authorized by JELD-WEN Inc.

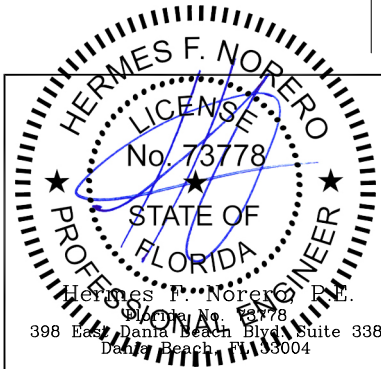

PROJECT ENGINEER: ---	DATE: 12/18/2017	JELD WEN	3737 Lakeport Blvd Klamath Falls, OR. 97601 Phone: (800) 535-3936	
DRAWN BY: A. MCMILLAN	SCALE: NTS			
CHECKED BY: J. GOOSSEN	TITLE: Premium Vinyl Fixed Casement Impact OOO Window - W22			
APPROVED BY: J. GOOSSEN				
PART/PROJECT No.:	D014460			
IDENTIFIER No. 110-17-049	PLANT NAME AND LOCATION:	CAD DWG. No.:	REV:	SHEET
		PremVinylFixedCsmt Cert	A	4 OF 4